

BRAINLIT

: A L V E N

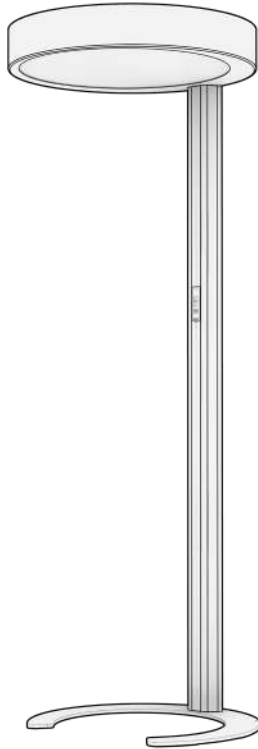

USER MANUAL

BioCentric Lighting™ Free Standing Luminaire

SAFETY INSTRUCTIONS

Before you use this device for the first time, please read the following notes in this manual and heed all warnings, even if you are familiar with handling electronic devices. Keep this manual safe for future reference. If you sell the device or pass it on, it is essential that you also hand over this manual.



This icon denotes important information for the safe operation for the product and for the user's safety.



This icon denotes further information on the topic.



WARNINGS/NOTIFICATIONS

- Please keep this User Manual and all related documents for future reference. You can also find information about this product and related services on our website www.brainlit.com.
- If your BrainLit Alven or any part of it is not functioning as intended, please contact the party you purchased BrainLit Alven from. Do not attempt to service, replace, or modify any part of BrainLit Alven yourself. BrainLit Alven should only be serviced by an authorized BrainLit service technician.
- BrainLit Alven weighs more than 20kg/44lbs. We recommend that assembly and moving of BrainLit Alven be handled by two people.
- BrainLit Alven is intended for indoor use only.
- For further safety information, please refer to Section 5.2 of this User Manual.

CONTENTS

1. Product information

| | |
|----------------------------|-----|
| 1.1 Product overview | p.4 |
|----------------------------|-----|

2. Assembly

| | |
|---------------------------------|------|
| 2.1 Before assembly | p.5 |
| 2.2 Assembly instructions | p. 6 |

3. Operation

| | |
|----------------------------------|------|
| 3.1 Manual operation | p.9 |
| 3.2 Operating instructions | p.12 |
| 3.3 Care & cleaning | p.13 |
| 3.4 Troubleshooting | p.14 |

4. Disclaimers

| | |
|---|------|
| 4.1 Data protection | p.15 |
| 4.2 Warranty & safety | p.16 |
| 4.3 Conformity | p.19 |
| 4.4 Repackaging, transportation & storage | p.20 |
| 4.5 Disposal | p.21 |

Thank you for choosing BrainLit Alven™. If you have any questions that are not covered in this manual, please get in touch with us for further assistance. Alternatively, visit our website for more information.

Contact:

info@brainlit.com
www.brainlit.com/brainlit-alven

PRODUCT OVERVIEW

About BrainLit Alven™

Light affects all species on Earth, especially humans. Evolution has made the natural variation of light essential for humankind, a need that hasn't changed despite the changes in our behavior.

Today most people spend 21 out of the day's 24 hours indoors, exposed to static and insufficient light. There are many well-documented and scientifically supported negative consequences stemming from exposure to poor light and how the lack of daylight affects our biology. These were the premises that led to the founding of BrainLit and the invention of BioCentric Lighting™ (BCL).

BrainLit Alven™ is the world's first personal, connected, dynamic and free-standing LED luminaire-powered BioCentric Lighting™ system. It is a multi-user system and can also be connected to the BrainLit cloud.

BrainLit's BioCentric Lighting™ creates an optimal natural lighting environment, with proper variations of light intensity and color at the right time of the day, synchronizing the body's circadian rhythm and the production of the necessary hormones (e.g., cortisol and melatonin) to keep your body system in balance.

The AutoLit recipe is the default setting that best helps you maintain your circadian rhythm. To maintain your normal circadian rhythm, you should use AutoLit as often as possible.

To learn more about the benefits of BioCentric Lighting™ please visit our website www.brainlit.com.

BEFORE ASSEMBLY

1. Remove all packaging materials.
2. Unpack and inspect all components.
3. Lay out all parts on a flat surface.



For indoor use only



Two people recommended for assembling and moving your Alven

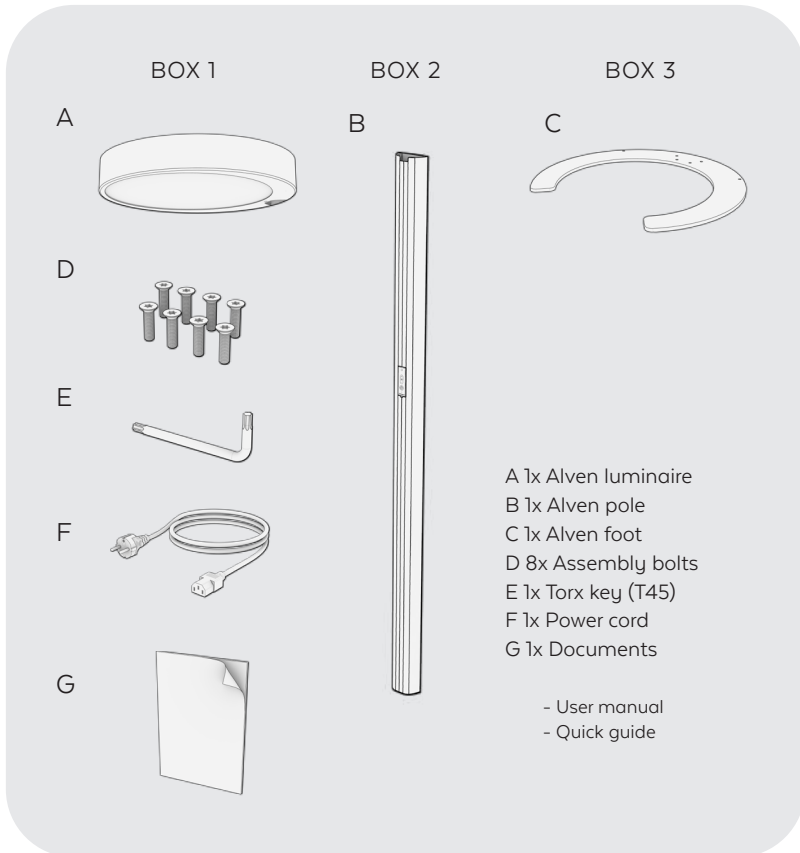

F The flexible cable or cord may be specially prepared and only available from the manufacturer or his service agent. (Power cord type IEC C13 to NEMA 5-15, UL approved)

ASSEMBLY INSTRUCTIONS

STEP 1

Attach foot to pole

Lay the pole (B) on a stool or chair horizontally to avoid damage, approximately 70 cm above floor as pictured below.

Attach the foot (C) to the bottom end of the pole (B) with four of the eight bolts (D) using the torx key (E).

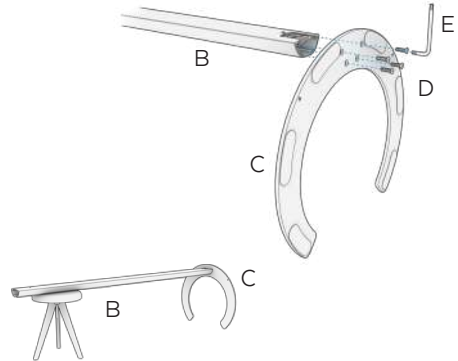
**STEP 2**

Attach luminaire to pole



NOTE: Please take care not to pinch or damage the wires.

Connect the wire and quick connector from the luminaire (A) with the matching connector from the pole (B), making sure they are firmly connected and that the latching hooks have connected properly.

Thread the luminaire (A) over the pole (B) and make sure that all cables are running free into the pole (B) and are not pinched or damaged.

Attach the luminaire (A) to the top end of the pole (B) with the remaining four bolts (D) using the torx key (E).

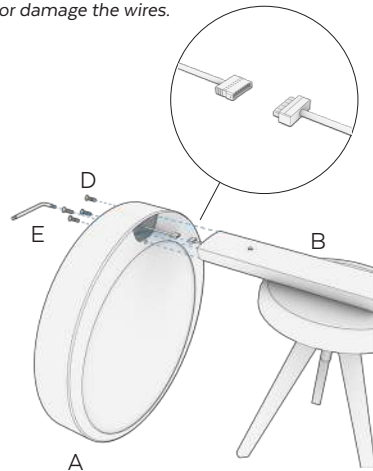

STEP 3

Connect power

Raise your Alven to a standing position with its foot on the floor.

Insert the power cable (F), first to your Alven and then to the wall outlet.

It will take about 2 minutes for your Alven to start once the power cord has been connected. Alven can be connected to a network using wifi or an ethernet cable (not provided).

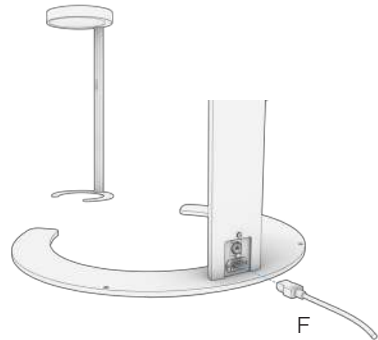

The flexible cable or cord may be specially prepared and only available from the manufacturer or his service agent.

Do NOT connect to a Power over Ethernet (PoE) connection. This device is not PoE compatible.



STEP 4

Start system

Use the power button to power your Alven On/Off.

Do not look directly into BrainLit Alven's light. It is brighter than a normal lamp and may cause discomfort.

For more features, see instructions in section 3.1 of this user manual or in the BrainLit app.

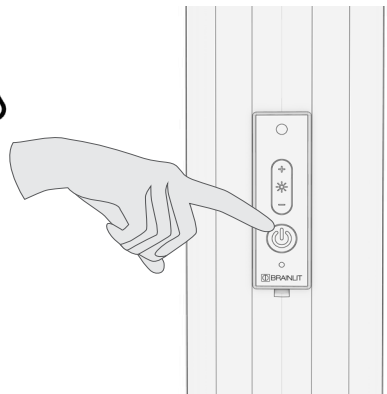

STEP 5

Complete set up

Complete the setup of your Alven by downloading the BrainLit app from the App Store or Google Play Store and follow the instructions.

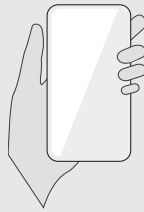

You're all set!
Welcome to the world of
BioCentric Lighting™.

MANUAL OPERATION

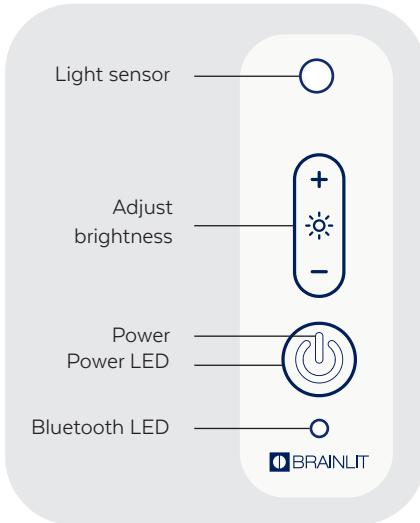

Normal Usage

By default, BrainLit Alven™ is in Auto-Lit mode. To best maintain your natural circadian rhythm, we recommend using AutoLit as often as possible.

If you adjust the brightness of BrainLit Alven using the (+) or (-) buttons on the physical keypad, the BrainLit app, or the online portal, you will exit the current light mode (AutoLit, Realx, Boost) and the light will remain at a static light intensity until you either activate a light mode again or you turn BrainLit Alven off and back on. The color temperature of the light will still follow the last selected light mode when setting static intensity.

LONG press  = Continuous brightening

LONG press  = Continuous dimming

Power = Toggle On/Off

LONG press Power = Enables changing of light settings

Toggle ON = Power LED is turned on for 0,5 sec

Toggle OFF = Power LED stays off

| Power LED status | Bluetooth LED status | Description | Status |
|-----------------------|----------------------|------------------------------------|--------------|
| OFF -> Pulsing slowly | OFF | System starting | Starting |
| Pulsing slowly -> OFF | OFF | System running | Normal usage |
| Blinks fast | OFF | Demo running | Demo |
| ON | Pulsing slowly | Bluetooth pairing possible | BT Pair |
| Blinks | OFF | Enables changing of light settings | Command |



It may take a few days for your eyes to adapt to the brightness of your BrainLit Alven™.

AutoLit

The AutoLit mode is the default setting that best helps you maintain your circadian rhythm. The circadian rhythm is referred to as our "biological clock" that regulates our well-being, alertness and sleep.

To maintain your normal circadian rhythm you should use AutoLit without dimming the light intensity as often as possible.



If you adjust the brightness of BrainLit Alven using the (+) or (-) buttons, you will exit AutoLit and the light will remain at a static light intensity until you turn BrainLit Alven off and back on.

Boost

Boost increases your alertness and stimulates your cortisol levels, giving you a refreshing effect. Recommended usage is a 20 minutes or shorter "light shower" preferably during the first half of the day (08.00-14.00).



Usage of Boost at night may disturb your natural circadian rhythm. To maintain your natural circadian rhythm, you should use AutoLit without dimming the light intensity as often as possible.

Relax

Relax creates a natural light environment that feels more neutral to your eyes but does not change dynamically and therefore has less impact on your circadian rhythm. Recommended usage is for shorter time periods after 14.00.



To maintain your circadian rhythm you should use AutoLit without dimming the light intensity as often as possible.

To activate AutoLit mode

Turn off, turn on => AutoLit

1. LONG press (3 sec) Power
2. Power LED blinks slowly
3. Within 7 sec SHORT press Power = mode changes to AutoLit

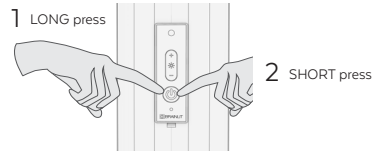

To activate Boost mode

1. LONG press (3 sec) Power
2. Power LED blinks slowly
3. Within 7 sec SHORT press **+** = scene changes to Boost

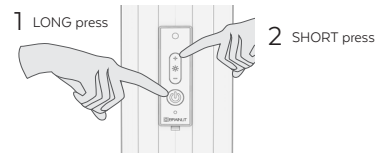

To activate Relax mode

1. LONG press (3 sec) Power
2. Power LED blinks slowly
3. Within 7 sec SHORT press **-** = scene changes to Relax

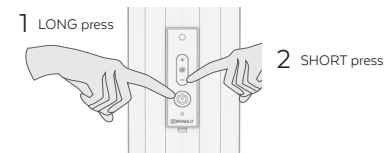

Bluetooth pairing - How to enable Bluetooth pairing mode on your BrainLit Alven™

1. LONG press (3 sec) Power
2. Power LED blinks slowly
3. Within 7 sec LONG press (3 sec)
4. Power LED is OFF and Bluetooth LED blinks slowly when pairing is active

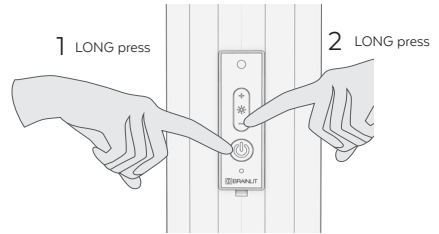

*Bluetooth pairing is active for 60 sec.
Follow instructions on your mobile device to complete pairing.*

AutoLit Demo - Shows the variation and dynamics of the light

1. LONG press (3 sec) Power
2. Power LED blinks slowly
3. Within 7 sec LONG press (3 sec)
4. Demo of AutoLit is running
5. Power LED blinks fast and Bluetooth LED is OFF when demo is running

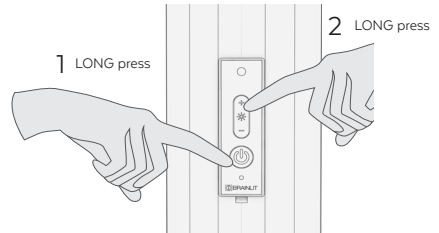

Demo will last for approximately 90 sec.

How to use your BrainLit Alven™ - Examples



The default AutoLit recipe is recommended as a standard setting as it helps you maintain your natural circadian rhythm. We encourage you to try different recipes and scenes, which can be found in the BrainLit app.

For example, you wake up one morning but feel a bit slow. This would be an optimal time to use the Boost scene for a short time to energize you for the day ahead. In the late afternoon or evening when you want a break, the Relax scene can be activated to create a calmer ambience for a short period of time.

We recommend using AutoLit during the majority of the day to maintain synchronization with your circadian rhythm.

OPERATING INSTRUCTIONS

1. Internet connection

BrainLit Alven™ is designed so that every user can enjoy a personal light environment. In order to provide optimal light recipes and maintain your personal circadian rhythm, Alven requires internet access to collect important user data.

An internet connection is also required to receive software updates, access to BrainLit's BioCentric Lighting™ recipe catalog, and other services, including connecting to other Alvens.

It is highly recommended to connect your BrainLit Alven™ to the internet in order to enjoy the system's full functionality.



Do NOT connect to a Power over Ethernet (PoE) connection. This device is not PoE compatible.

2. Mobile app

The BrainLit app can be downloaded from the Google Play Store or the App Store.

The app makes it possible to connect your BrainLit Alven™ to a wifi network. Please see further instructions in the app.

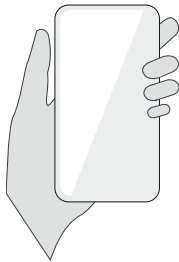

CARE & CLEANING

All cleaning and external maintenance of BrainLit Alven should be performed by adults.

To remove dust, please use a dry microfiber cloth to wipe BrainLit Alven. To remove smudges or other dirt, please use a small amount of a standard household cleaning agent to remove.



If your BrainLit Alven is not functioning as intended, please contact the party you purchased BrainLit Alven from. BrainLit Alven should only be serviced by an authorized BrainLit service technician.

TROUBLESHOOTING

Restart BrainLit Alven

If you experience problems with your BrainLit Alven, you can try to restart it. That can be done in two ways that are described below. Please try the first alternative first and if your problem is still not resolved, try the second alternative.

1. Restart BrainLit Alven from the keypad:

Press and hold the power button for 10s. After 10s, the power button LED and the bluetooth LED start blinking rapidly. The BrainLit Alven will restart 3s. after that.

2. Unplug the power cord:

Unplug the power cord and after 30s, connect the power cord again. The BrainLit Alven will take approx. 2 minutes to restart.

BrainLit Alven not showing up in available devices on the BrainLit app

1. If BrainLit Alven is not showing up in the Bluetooth device scanning list, verify from your mobile device's Settings > Bluetooth menu that Bluetooth is enabled by toggling it off/on.
2. If the BrainLit Alven is still not showing up on list, try restarting your BrainLit Alven as explained above. After your BrainLit Alven is restarted you can continue the pairing process.
3. Ensure that BrainLit Alven is in pairing mode (blue light blinking) while you are attempting to connect.

BrainLit Alven does not connect to WiFi

1. Ensure that your internet connection is active and that your mobile device is connected to BrainLit Alven. If necessary, restart your BrainLit Alven as explained above.
2. Your BrainLit Alven may be located too far from your WiFi router. Try turning the keypad towards the router or moving BrainLit Alven closer to your WiFi router.

The bluetooth connection to the BrainLit Alven is unstable

1. Unpair from your BrainLit Alven and pair again
 - 1.a On an iOS device, make sure to “forget” your BrainLit Alven in your bluetooth devices before pairing to your BrainLit Alven again. You don’t need to do that on an Android device.
2. If the bluetooth connection is still unstable, try restarting your BrainLit Alven as explained above.

AutoLit light recipe does not appear to be in sync with my local time zone

1. BrainLit Alven matches the time zone of your mobile device. Check to ensure that your mobile device time zone is set to the local time. You can also check the time zone of your BrainLit Alven (that should be the same as your mobile device) by tapping on the cog icon on the device details page and going to “System Info”. The time zone information is available only if you’re connected to your BrainLit Alven via bluetooth.

If there are other problems you are not able to solve, please contact the party you purchased your BrainLit Alven from for support or email info@brainlit.com.

4.1

DATA PROTECTION

Managing and storing personal data

BrainLit Alven™ is a system that relies on user data to reach its full potential. In order for your BrainLit Alven™ to function at its best, you have to accept our terms and conditions. BrainLit AB follows all laws and regulations regarding the use, management, and maintenance of your personal data, following the EU’s GDPR protocols. Read more about our privacy policy and data management practices at www.brainlit.com/privacy-policy



WARRANTY & SAFETY

Safety

- To reduce the risk of fire, electric shock or injury please read the following documentation carefully.
- Secure Alven to the floor using screws and bolts according to local rules/building standards to avoid tilting accidents.
- Do not look directly into the Alven lamp. It is brighter than a normal lamp and may cause discomfort.
- The light source of this luminaire is not replaceable; when the light source reaches its end of life, the whole luminaire should be replaced.
- Changes or modifications not expressly approved by the party responsible for compliance could void the user's authority to operate the equipment.
- The Alven system should be used by people with reduced physical, sensory or reasoning capabilities, or lack of experience and knowledge, only if they have been given supervision or instruction by a responsible person concerning use of the light in a safe way and understand the hazards involved. All cleaning and maintenance of the system must be performed by adults.
- Alven is not a toy. Please take extra care when the system is in use near children.
- Ensure the system is fully assembled according to the instructions before use.
- Suitable for indoor use only 0°C (32°F) – 40°C (104°F).
- Use only as described in the Alven User Manual. If assistance is required, please contact the party you purchased your BrainLit Alven from or contact BrainLit support at info@brainlit.com.

- If Alven is faulty or does not work correctly due to any type of external factors such as low/high temperatures, exposure to water or other damages, turn off the system and contact BrainLit support.
- If service or repair is needed, please contact the party you purchased BrainLit Alven from or contact BrainLit support. Never attempt to repair, service, or modify BrainLit Alven yourself. Service should only be conducted by an authorized BrainLit technician.
- BrainLit Alven's wired internet connection should not be used with Power over Ethernet (PoE) outlets as this may damage the system. Please confirm that no power is delivered through your wired ethernet connection prior to connecting BrainLit Alven.
- Do not handle any part of Alven with wet hands.
- Do not use Alven if any cables or plugs are damaged.
- Do not place Alven where cables can pose potential safety hazards in its surroundings, such as where cables may come in contact with hot surfaces or cause trip accidents.
- When connecting the BrainLit Alven pole to the luminaire, be careful to ensure that the wires connecting the two do not get pinched or damaged.
- Take care when unplugging Alven. To unplug, grasp the plug, not the cable.
- Unplug BrainLit Alven from the socket when not in use for extended periods.
- Do not use near furnaces, fireplaces, stoves or other high temperature heat sources.

Warranty

Alven comes with a 1-year warranty which is valid from the time of purchase or date of delivery if this is a separate date.

The warranty covers the following:

1. The repair or replacement of your Alven system (at BrainLit's discretion) if it is found to be defective due to faulty materials, workmanship or function within 1 year of purchase or delivery (if any part is no longer available or out of manufacture, BrainLit will replace it with a functional replacement part).
2. Please note that the warranty will only be valid if Alven is used in the country in which it was purchased.

The warranty does not include:

1. Damage caused by insufficient maintenance.
2. Accidental damage, faults caused by negligent use or care, misuse, neglect, carelessness or operation or handling of the light which is not in accordance with this user manual.
3. Use of the Alven system for any other purpose than for what it is designed for.
4. Use of parts not assembled or installed in accordance with the instructions in this user manual.
5. Use of parts and accessories which are not provided by BrainLit.
6. Faulty installation (except where installed by BrainLit).
7. Repairs or alterations carried out by parties other than BrainLit or authorized BrainLit partners.
8. Normal wear and tear.

If you have any questions regarding your warranty, please contact the party you purchased your BrainLit Alven from.

CONFORMITY

EC Declaration of Conformity

Hereby, BrainLit declares that this product is in compliance with the essential requirements and other relevant provisions of Directive 2014/53/EU.

FCC

This device complies with part 15 of the FCC Rules. Operation is subject to the following two conditions: (1) This device may not cause harmful interference, and (2) this device must accept any interference received, including interference that may cause undesired operation.

FCC Caution

Changes or modifications not expressly approved by the party responsible for compliance could void the user's authority to operate the equipment

Frequency Tolerance: ± 20 ppm

This transmitter must not be co-located or operated in conjunction with any other antenna or transmitter.

This equipment complies with FCC radiation exposure limits set forth for an uncontrolled environment and meets FCC radio frequency (RF) Exposure Guidelines. This equipment should be installed and operated keeping the radiator at least 20 cm or more away from person's body.

RE-PACKING, TRANSPORTATION AND STORAGE

We recommend retaining the packaging of your BrainLit Alven in case you need to store or transport it in the future. Each item can be safely re-packed using the provided packing material and styrofoam.

If disassembling BrainLit Alven for longer periods of time, we recommend storing BrainLit Alven in its original packaging to reduce wear and tear or the accumulation of dust.

DISPOSAL



BrainLit Alven is an electronic device and should only be disposed of according to local regulations for the recycling or disposal of electronics. BrainLit Alven should not be disposed of as common waste.

All packaging cartons are recyclable and should be recycled according to local regulations. Styrofoam and other elements should be sorted according to local regulations.

We'd love to hear from you.

We hope you find everything you need
in this manual.

If you have any questions about BrainLit Alven™
or any other enquiries, please get in touch
with us via email.



info@brainlit.com

BrainLit was founded in 2012 in Sweden by Tord Wingren, one of the inventors of Bluetooth technology.

We provide healthy environments, recreating daylight indoors using personally adapted light. BioCentric Lighting™, based on firmly established research and a number of patent groups, is the basis of our solution.

Our vision is to improve peoples' quality of life through Biocentric Lighting™.

